

REVEALING THE UNIQUENESS OF VARIATIONS IN PROSPECTIVE TEACHERS' METACOGNITIVE ACTIVITIES IN SOLVING MATHEMATICAL PROBLEMS BASED ON GENDER

Ramlah, Tatag Yuli Eko Siswono*, Agung Lukito
Universitas Negeri Surabaya, Indonesia

Article Info

Article history:

Received Mar 29, 2023
Revised May 10, 2024
Accepted Jun 3, 2024
Published Online Jun 12, 2024

Keywords:

Gender,
Mathematical Models,
Mathematical Problem-Solving,
Metacognitive Activities,
Prospective Teachers

ABSTRACT

A significant amount of scholarly investigation has recently focused on metacognitive activity. However, the examination of metacognitive variations in solving math problems that are still limited in scope. This case study examines gender differences in activity variations of metacognitive activities, specifically awareness, regulation, and evaluation, in prospective teachers solving mathematical problems based on mathematical models. Participants were selected through purposive sampling. Twelve male and sixteen female participants were chosen from those who participated in the 'capita selecta' mathematics course at a public university in West Java, Indonesia. The data were collected through mathematical problem-solving tasks and interviews. The results show that the variations in metacognitive activities between male and female participants are different. Females tend to be more complex and structured in their evaluation activities, while males tend to be more complex and structured in their awareness activities. Based on the results, recommendations are made for future studies.

This is an open access article under the [CC BY-SA](#) license.



Corresponding Author:

Tatag Yuli Eko Siswono,
Department of Mathematics Education,
Universitas Negeri Surabaya
Jl. Lidah Wetan, Lakarsantri, Surabaya, East Java 60213, Indonesia
Email: tatagsiswono@unesa.ac.id

How to Cite:

Ramlah, R., Siswono, T. Y. E., & Lukito, A. (2024). Revealing the uniqueness of variations in prospective teachers' metacognitive activities in solving mathematical problems based on gender. *Infinity*, 13(2), 477-500.

1. INTRODUCTION

Studies on metacognition in problem-solving have significantly progressed, particularly in mathematics education (Kayashima et al., 2005; Laamena & Laurens, 2021; Permadi & Irawati, 2023). Previous research has shown that metacognition plays a crucial role in determining the success or failure of solving mathematical problems (Bakar et al., 2021; Gurat & Medula Jr, 2016; Kaune et al., 2011; Magiera & Zawojewski, 2011; Ozturk, 2016; Panaoura & Philippou, 2005). Metacognition, as explained by Flavell (1979), refers to cognitive processes involving individual awareness of the acquisition of knowledge and the ability to organise knowledge. Metacognitive activities during problem-solving

performance in early and later phases have been a significant focus of previous researchers (Goos, 2002; Schoenfeld, 1987; Stillman & Galbraith, 1998; Zan, 2000).

Metacognitive activities involve cognitive processes when solving mathematical tasks, particularly metacognition (Hastuti et al., 2016). This mental activity can increase and grow individual metacognitive awareness (Temur et al., 2019). Metacognitive activities in solving problems include three components, namely awareness, regulation, and evaluation (Magiera & Zawojewski, 2011; Wilson & Clarke, 2004). Metacognitive awareness is an individual's awareness during the problem-solving process, the problem-solving strategies used to solve the problem, the individual's previous knowledge and the unique knowledge needed to solve the problem. Metacognitive regulation is an individual's knowledge about the strategies chosen and used, including how and why the individual uses these strategies. Meanwhile, metacognitive evaluation is a decision taken by an individual regarding the results of their thinking, the limitations of their thinking in problem situations, and the limitations of individual strategies in solving problems.

There are two terms in understanding a person's metacognitive activity in solving problems: between 'shifts' and 'variations.' Shifts indicate progress or significant changes in a person's metacognitive activities, while variations indicate their ability to adapt their metacognitive activities to different situations. Metacognitive activity shifts can be grouped into constructive and perfunctory metacognitive activity shifts. Constructive metacognitive activity shifts involve the awareness and evaluation components of metacognitive activity. The shift in perfect metacognitive activity involves the components of awareness, evaluation, and regulation of metacognitive activities (Hastuti et al., 2016).

Indeed, investigating metacognitive processes (i.e., awareness, regulation, and evaluation) in the context of mathematical problem-solving remains a pressing and exciting area of research today. Research conducted by Magiera and Zawojewski (2011) aimed to characterise problem-solving scenarios associated with spontaneous metacognitive activities in small group conversations among ninth-grade students. Hastuti et al. (2016) investigated changes in creative metacognitive activity in junior high school students when solving mathematics problems. Additionally, Gurat and Medula Jr (2016) researched the utilisation of metacognitive methods by prospective instructors during implementing metacognitive tasks. However, their research is limited to examining behavioural, character and metacognitive process changes when elementary or middle school students solve math problems. Limited research investigates this topic among prospective mathematics teachers. Research conducted by Pathuddin et al. (2019) mainly examined male students' metacognitive activities, especially their cognitive styles. Research conducted by Panjaitan (2016) centred on exploring differences in metacognitive activity during the assessment process. However, their research was limited to reviewing behavioural, character and metacognitive process changes when elementary or middle school students solve math problems.

The discussion regarding the limitations of previous research above is strengthened by the findings of a preliminary study conducted at a state university in West Java, Indonesia. This research focused on prospective mathematics teacher students and involved the administration of mathematics problem-solving tasks. Findings showed that most (80%) students concentrated on describing the final solution when solving mathematical problems. Based on the results obtained, it can be seen that only 20% of male students achieved success in overcoming this problem.

Based on the obstacles observed in previous research and the findings from the initial investigation, the researcher was motivated to explore the occurrence of differences in metacognitive activities between male and female perspective mathematics teachers when solving mathematical problems. This inquiry aims to develop a mathematical model to

effectively address and solve these problems. Examining variation plays a vital role in understanding the metacognitive processes used by prospective educators when engaged in problem-solving tasks. To prioritise these studies, it is critical to speed up their implementation. Given these circumstances, researchers sought to address the gap in the existing literature due to the lack of research examining the influence of gender on prospective teachers.

The study aims to report and provide descriptive data about gender-based differences in metacognitive activities among prospective teachers when solving mathematics problems. Therefore, this research offers a valuable contribution to the progress of science, especially in metacognition literature studies. Specific contributions to the mathematics learning process at the university level include lecturers' considerations in determining strategies, approaches, modules, and evaluation sheets that align with the frequency of variations in metacognitive activities and habits. These factors are critical in facilitating the development of practical problem-solving skills and the creation of powerful mathematical models for the future teaching of teacher candidates. Furthermore, further investigation is needed to overcome the obstacles inherent in the research conducted by Hastuti et al. (2016) and Panjaitan (2016) regarding examining variations in metacognitive activities among students.

2. METHOD

This research uses a qualitative case study approach to examine the variability of metacognitive awareness, regulation, and evaluation activities proposed by Magiera and Zawojewski (2011) and De Backer et al. (2016) among prospective mathematics teachers. Variations in metacognitive activity are observed through problem-solving tasks that utilise mathematical models. Furthermore, this research aims to elucidate the components of metacognitive activities, namely awareness, regulation, and evaluation, and their manifestation during the cognitive task-solving process.

This research involved 58 prospective mathematics teachers, 19 males and 39 females, enrolled at a state university in West Java, Indonesia.

Table 1. Descriptive statistics

Descriptive statistics	Male	Female
N	19	39
Minimum	65	68
Maximum	86	85
Reach	21	17
Average	79	79
Standard Deviation	6.40	4.42
n (participants) > Average	12	16

Based on the data in [Table 1](#), prospective mathematics teachers were identified as potential participants, including twelve males and sixteen females. The selection of participants utilised a purposive sampling technique (Miles et al., 2014). This technique was chosen because it aligned with the expected goal that the participants could provide in-depth information and be considered to have relevant insights, experiences, or characteristics. Participants were selected based on the following criteria: the first criterion being scored above the average. This was chosen because someone who can solve problems well has good metacognitive awareness as well (Desoete et al., 2001; Händel et al., 2013; Khasanah, 2021;

Yıldız & Dökme, 2017). The second criterion is that participants can solve math problems with systematic stages (identification, planning strategies, solving problems, and re-examining the results). The third criterion is that participants are willing to be a source of information.

2.1. Data Collection Process

Prospective mathematics teachers were assigned problem-solving tasks supported by auxiliary instruments consisting of mathematical problems based on models and unstructured interviews. The instruments were validated for internal validity by two experts, resulting in a high validity rate of 95.8%. The problem-solving task based on mathematical models, specifically involving linear equations, follows a process that represents a mathematical model. This task was adapted from Juniati (2020).

Problem-solving tasks:

Andre and Nia have been friends since childhood. If Andre were Nia's age now, Nia would be 12 years old. When Andre is 36, Nia will be Andre's age now. Find Nia's current age. Present a mathematical model of the problem and solve it!

Participants received a written problem-solving task within a 30-minute timeframe. They were instructed to articulate their thoughts throughout the process, known as 'think-aloud,' from beginning to end. The study examined metacognitive activities based on the stages of the thinking process aligned with the problem-solving stages. Table 2 outlines the components of metacognitive activity.

Table 2. Components of metacognitive activities (adapted from De Backer et al., 2016)

Metacognitive Activity Components	Information
Awareness	Statements regarding individual reflection on the results of their mathematical cognition, explicitly discussing: <ol style="list-style-type: none"> Existing understanding of mathematical problem-solving tasks (AMA01). Relevant mathematical knowledge required for mathematical problem-solving tasks (AMA02). Application of mathematical problem-solving strategies (AMA03). Steps required to complete a math problem-solving challenge (AMA04). What steps have been used or have the potential to be applied to overcome mathematical problem-solving challenges (AMA05).
Regulation	Individual discourse regarding the results of their mathematical cognition is related to the following: <ol style="list-style-type: none"> Formulate a systematic approach to solving mathematical difficulties (AMR01). Identify alternative methodologies used to solve mathematical problems (AMR02). Determine the following mathematical problem-solving action (AMR03). Selecting appropriate problem-solving techniques that will be implemented effectively (AMR04).

Metacognitive Activity Components	Information
Evaluation	<p>An individual's evaluation of their mathematical thinking, explicitly focusing on the following aspects:</p> <ol style="list-style-type: none"> Individual assessment of the abilities and limitations of the thinking process and its results (AME01). Effectiveness of the problem-solving strategy chosen by the individual (AME02). Evaluation of the individual's answers or final results (AME03). Assessment of any difficulties encountered when completing mathematics problem assignments (AME04). Individual self-assessment of their Problem-solving abilities (AME05).

Furthermore, to show the unique variations of metacognitive activities, each indicator component is depicted with coloured symbols in Figure 1. The circles, triangles, squares, numbers and arrows represent variations of metacognitive activities. The circle symbol is characterised as the awareness component of metacognitive activity. The triangle symbol is marked as the organisational component of the metacognitive activity. The square symbol is marked as the evaluation component of the metacognitive activity. Each metacognitive activity component has sub-indicators marked with number codes (e.g. code 01, 02, and so on) according to the number and order (see Table 2) within each symbol. The numbers (1, 2, 3, and so on) placed outside the symbols indicate how the metacognitive activities occur. Orange-coloured arrows indicate the order of the process of metacognitive activities performed by Participant R1. Participant R2 shows blue arrows, participant R3 shows pink arrows, and participant R4 shows black arrows.

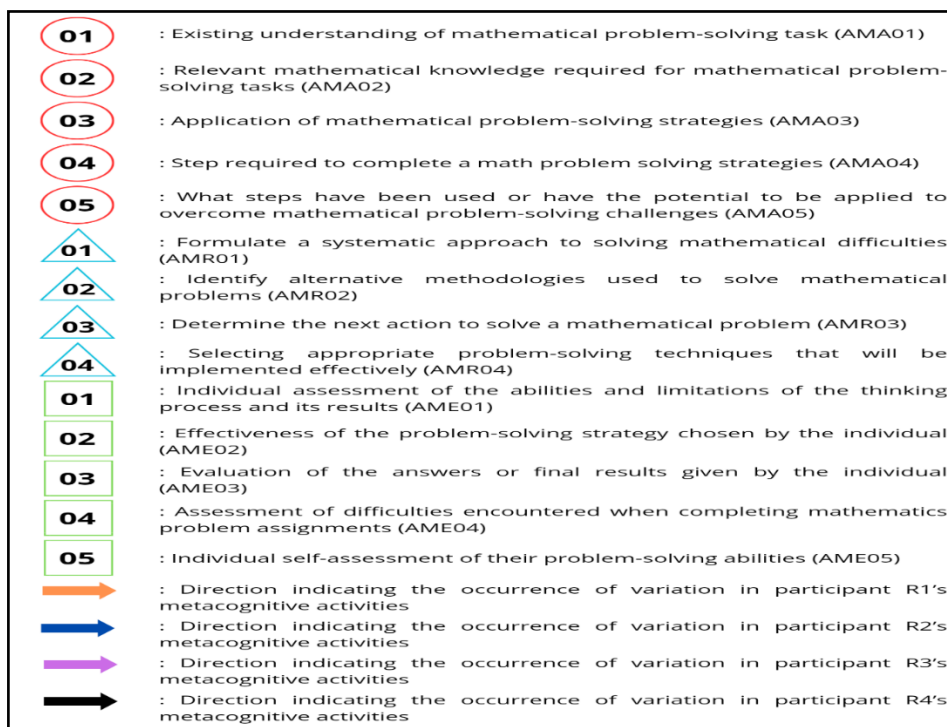

Figure 1. Meaning of symbols in metacognitive activities

In addition, the research employed the think-aloud method. This method involves prospective mathematics teachers verbalising their thoughts while completing problem-solving tasks, expressing 'what comes to mind' (van Someren et al., 1994). Unstructured interviews were also conducted to unveil information not captured by previous data collection methods.

The interview questions focused on three components of metacognitive activity, as shown in Table 2. The interviews were conducted after the analysis of problem-solving task results. The interviews were conducted individually, lasted approximately 30 minutes, and took place online via WhatsApp video call. The interviews were conducted after analysing problem-solving task results, and factors such as readiness (physical space and internet connectivity), participant availability, and overall conditions were considered. The interviews were conducted after analysing problem-solving task results, and factors such as readiness (physical space and internet connectivity), participant availability, and overall conditions were considered. The following criterion followed the procedure for solving mathematical problems. The results of the problem-solving tasks undertaken by male and female prospective mathematics teachers are presented in Figures 2 and 3.

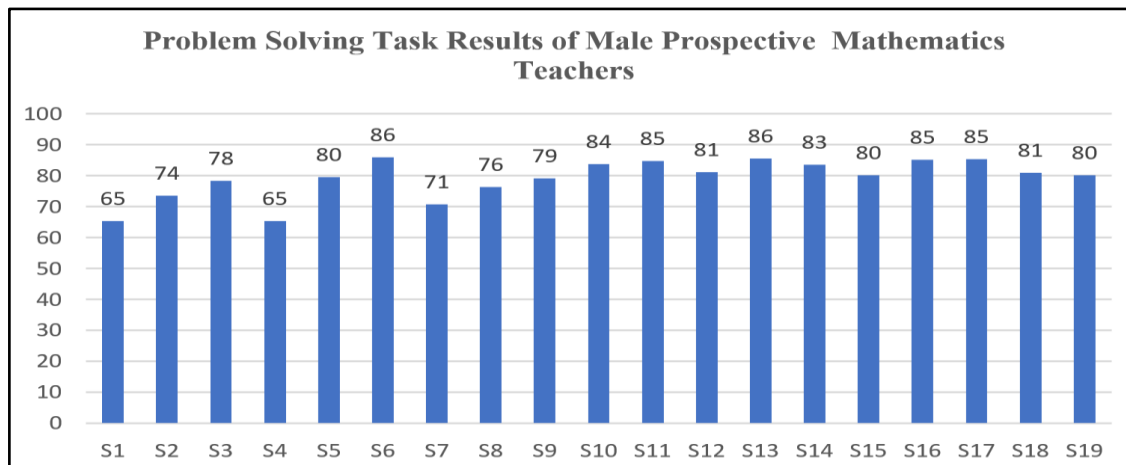

Figure 2. Results of mathematics problem-solving tasks of male prospective mathematics teacher

Figure 2 shows that male prospective mathematics teachers S5, S6, S10, S11, and S19 meet the first criteria as prospective participants. At the same time, female prospective mathematics teachers who meet the first criteria are S20 to S25, S34, S37, S38 to S48, and S58. Furthermore, the determination of participants in each group meets the second criterion. Based on these considerations, four participants were determined, two from each group, namely S13 and S18 (male participants) and S22 and S42 (female participants). After the participants were chosen, they were coded R1 (S22) and R2 (S42) as female participants. At the same time, R3 (S13) and R4 (S18) were male participants.

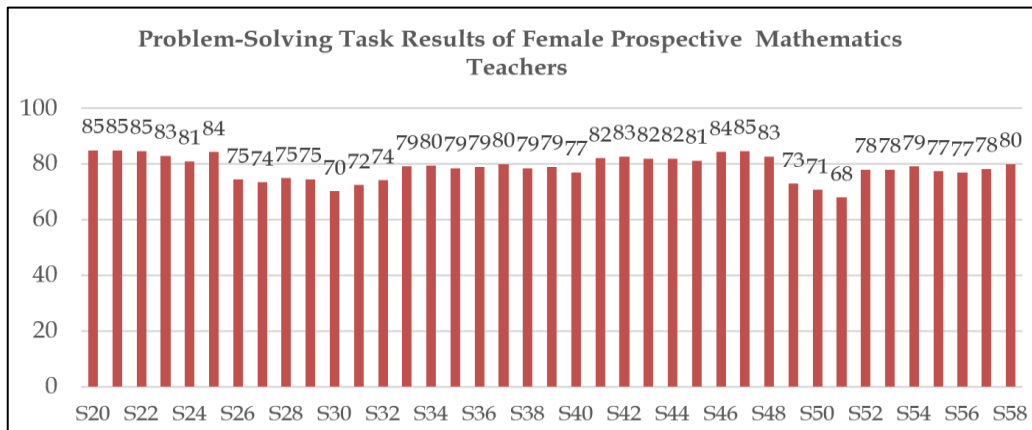

Figure 3. Results of mathematics problem-solving tasks of female prospective mathematics teacher

2.2. Data Analysis Process

Data analysis in this research involved three stages: data summarization, presentation, and conclusion drawing (Miles et al., 2014). During the summarisation stage, the researcher condensed all available data, emphasising key points to transform lengthy sentences into concise ones. The summarized data resulted from problem-solving tasks, including written responses and think-aloud recordings. Subsequently, this data was cross-referenced with interview data to validate accuracy. Collected data, encompassing voice recordings and interview notes, was transcribed and summarised.

Following data collection, the researcher selected and systematically organised the information, presenting it as a narrative. Additionally, a flow diagram was employed to illustrate distinct metacognitive behaviour observed among female and male participants in teacher education programs. This visual aid aims to enhance understanding of fundamental differences between observed variations, showcasing practical metacognitive activities in a structured framework encompassing awareness, regulation, and evaluation stages. The concluding stage involves drawing insights from information obtained from participants. Before reaching this final stage, the researcher employed the triangulation method and considered time to fortify the conclusion's validity. In this study, all qualitative data were collected and descriptively analysed.

3. RESULT AND DISCUSSION

3.1. Results

This section presents a descriptive overview of the results of data analysis regarding the changes observed in metacognitive activities, especially awareness, regulation, and evaluation, in female participants (R1 and R2) and male participants (R3 and R4) when involved in mathematical model-based learning problem-solving tasks. The metacognitive processes of each participant are visualised in the flow diagrams in Figures 4, 7, 11, and 13.

Variations in participants R1, R2, R3, and R4 metacognitive activities are presented in stages. The description of metacognitive activities is based on the results of think-aloud and interviews.

3.1.1. Description of variations in metacognitive activities of female participants (R1)

The diversity of metacognitive activities identified by undergraduate participants started from identifying problems, planning solutions, drawing up plans, and reviewing the results of solving mathematical problems. The three components of metacognitive activity are well-identified. However, the variation of activity that is most frequently carried out is evaluation, while several other metacognitive activity components are only identified in small numbers. The flowchart of variations in metacognitive activity that occurs is presented in Figure 4.

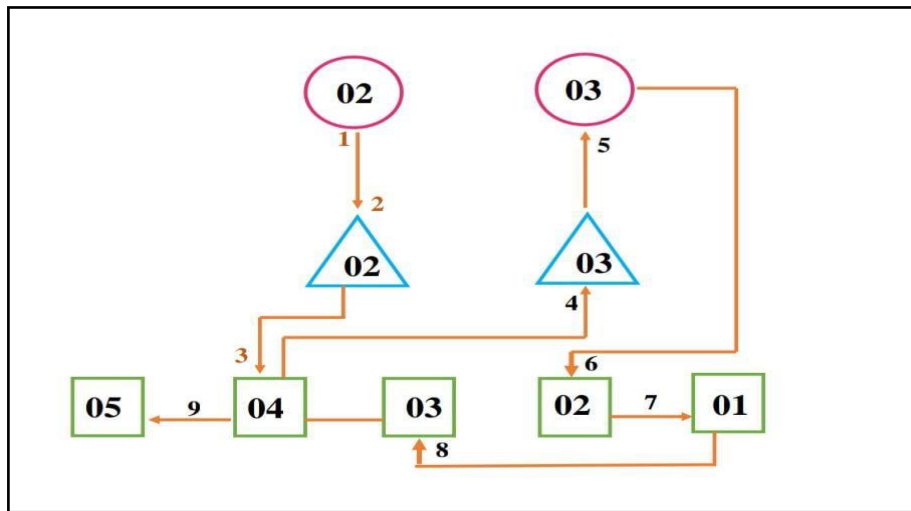

Figure 4. Flowchart of variations in the metacognitive activity of female participants (R1)

Figure 4 explains the variation of metacognitive activities in Participant R1 when solving math problems. The circle symbol with code 02 is marked as a component of awareness metacognitive activity in the second and third sub-indicators (AMA02 and AMA03). Triangle symbols with codes 02 and 03 are marked as components of regulatory metacognitive activity with the second and third sub-indicators (AMR02 and AMR03). Square symbols with codes 01, 02, and up to 05 are marked as components of evaluation metacognitive activity with the first, second, and fifth sub-indicators (AME01, AME02, up to AME05). The numbers 1 to 9 outside the symbols indicate the order of metacognitive activities.

Metacognitive awareness activities facilitated with think-aloud techniques for undergraduate participants provide insight into mathematical knowledge about linear equations related to given mathematical problems (AMA02). The participant in this study used the think-aloud method during metacognitive activities, organising AMR02 to articulate their thinking processes. Specifically, they use a problem-solving approach that involves recognising existing problems by generating examples from already-known knowledge. Interview excerpts provide evidence that supports the use of think-aloud activities.

Q : *What steps are determined based on the chosen strategy?*

R1 : *Once a comprehensive understanding of the situation is achieved, assumptions are made based on the available information. The variable 'x', representing age, is then identified, and a mathematical model is created. Andre's current age is the same as Nia's. This relationship is represented by the $x-12$ mathematical model, where x represents their age. The mathematical model representing Nia's current age is symbolised by $36-x$, as stated in equation (2) (see Figure 5).*

• umur andre yang seumur nia sekarang $x - 12$ (1)	Translation :
• umur nia sekarang $36 - x$	• Andre is the same age as Nia now $x - 12 \dots (1)$
	• Nia's age now $36 - x$

Figure 5. Mathematical model of participant (R1)

Metacognitive evaluation activities (AME04) were confirmed by implementing think-aloud exercises. Participants faced challenges in problem-solving, especially in the process of converting ordinary phrases into mathematical models. The metacognitive activities of AMR03 regulation and AMA03 awareness were confirmed by implementing think-aloud activities. During this activity, participants faced challenges in solving problems, thus encouraging them to strategically determine the following action to solve mathematical problems, especially by determining the value of the variable x in Figure 6.

Q : What are the reasons for facing challenges in solving this problem?

R1 : The ability to understand a situation hinders my ability to resolve it.

Q : What actions do you propose to address existing problems?

R1 : The initial response to the prompt was contemplation and uncertainty. The next step involved in the process is balancing equations (1) and (2), determining the value $x=24$.

umur nia sekarang = umur andre $36 - x = x - 12$	Translation: Nia's age now = Andre's age
$36 + 12 = x + x$	$36 - x = x - 12$
$48 = 2x$	$36 + 12 = x + x$
$x = \frac{48}{2}$	$48 = 2x$
$x = 24$	$x = \frac{48}{2}$
	$x = 24$

Figure 6. Problem-solving process of female participant (R1)

In a comprehensive metacognitive evaluation exercise, R1 determined that the method effectively solved a mathematical problem while facing challenges in understanding the problem and harbouring uncertainty regarding the accuracy of the strategy used. In conclusion, R1 gave an inappropriate response by setting the variable x equal to 24, resulting in Nia's age being 24 years. The findings mentioned above come from the results of the think-aloud exercise.

3.1.2. Description of variations in metacognitive activities of female participants (R2)

Even though R2 experiences all types of metacognitive activity, not all aspects of metacognitive activity occur in a complete and structured manner. It can be concluded that the metacognitive activity most frequently carried out is evaluation, compared to the other two aspects, namely awareness and regulation.

Figure 7 shows a flow diagram of variations in metacognitive activities carried out by R2 participants. From the flow diagram, it can be seen that R2 experienced the same three

types of metacognitive activities as the other participants. However, the order and frequency of metacognitive activities carried out by R2 were different from those of other participants.

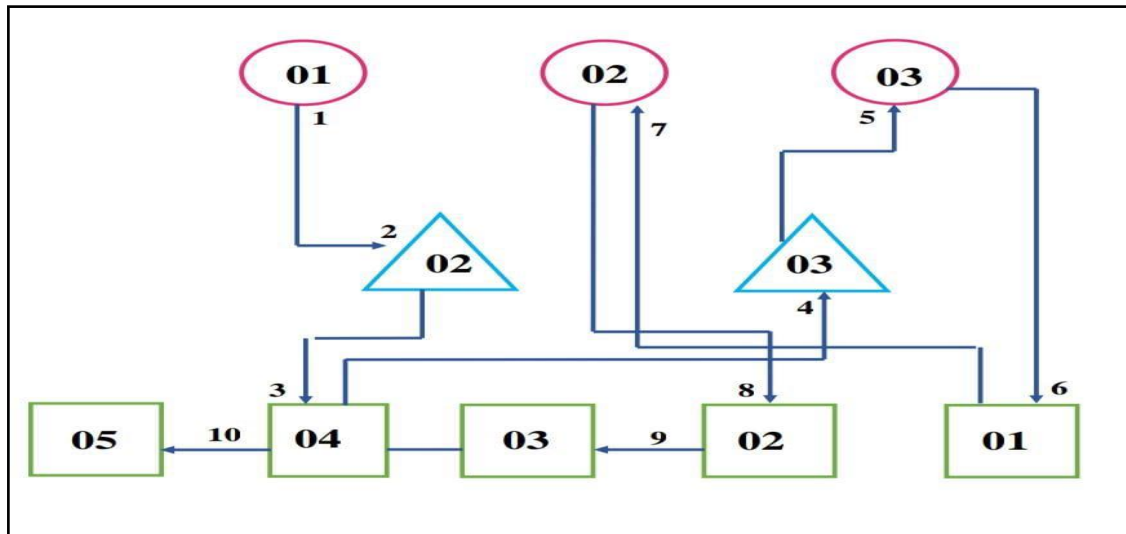

Figure 7. Flowchart of variations in metacognitive activities of female participants (R2)

Figure 7 explains the variation of metacognitive activities in participant R2 while solving math problems. The circle symbol with code 01 is marked as the awareness metacognitive activity component of the first sub-indicator (AMA01), and so on. The triangle symbol with code 02 is marked as a component of regulation metacognitive activity with the second sub-indicator (AMR02) and so on. The square symbol with code 01 is marked as a component of evaluation metacognitive activity with the first sub-indicator (AME01) and so on. The numbers one until ten outside the symbol indicate the order of metacognitive activities.

Participant R2 communicated the results of their cognitive processes during the think-aloud task by understanding terms and facts they were familiar with and asking about any uncertainties. However, they are reluctant to write it on the answer sheet. Verification of this metacognitive activity is not proven by think-aloud activity. R2 demonstrated challenges in understanding the situation at hand, thus using a methodical approach to ensure strategies were used for problem-solving. This approach involves repeated reading, identifying pertinent keywords, replacing those keywords with appropriate mathematical symbols, and converting known information into an appropriate mathematical model. The following is an excerpt from the interview.

Q : Do you know the extent to which the information provided on this subject is comprehensive or needs to be more complete?

R2 : I did not realise that the problem was difficult to understand, so the information acquisition was less than optimal.

Q : Do you know the proper method to solve this problem? After carrying out a careful inspection and repeatedly reading about the existing problems,

R2 : I do not set a strategic approach; instead, I consider 'Nia's age' as the independent variable, denoted by x , and 'Andre's age' as the dependent variable, denoted by y . Additionally, I converted regular statements into mathematical expressions (see Figure 8).

Q : What actions are determined based on the chosen strategy?

R2 : I ascertain the procedures required to solve the problem in this section.

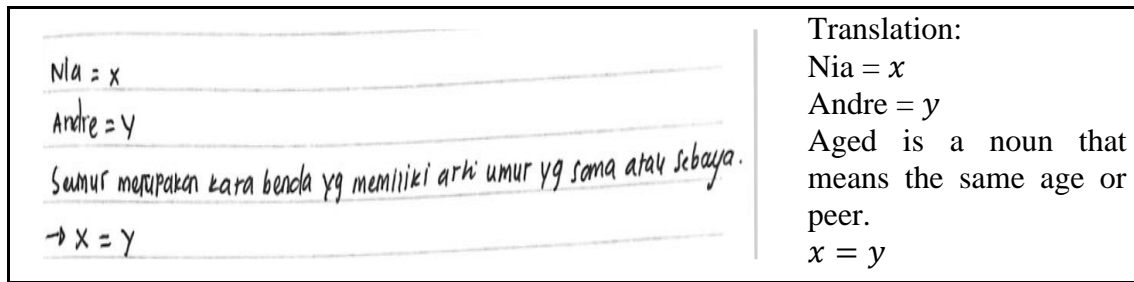

Figure 8. Mathematical models presented of female participants (R2)

In the metacognitive evaluation activity AME04, R2 participants assessed the challenges experienced when solving mathematical problems. R2 confirmed that he did not encounter any obstacles during the problem-resolution procedure. In metacognitive activity AMR03, R2 determines other actions that will be used to solve mathematical problems by carrying out analysis based on the information presented. The think-aloud results were not confirmed, but information was obtained from interviews.

- Q : *What strategies can guide the problem-solving process effectively and mitigate potential challenges?*
 R2 : *I see no significant challenges in this matter because I have read a lot and obtained relevant information about the problem-solving process.*
 Q : *What is your problem-solving process?*
 R2 : *I carried out an analysis of the problem, where the word 'age' is a noun that means the same age or the same age so that the sentence 'Andre was now that old when Nia was 12 years old' can be made into a mathematical model, namely $x=y$. I use the '=' sign because it corresponds to the meaning of 'lifelong', which means Andre and Nia are the same age (see [Figure 9](#)).*

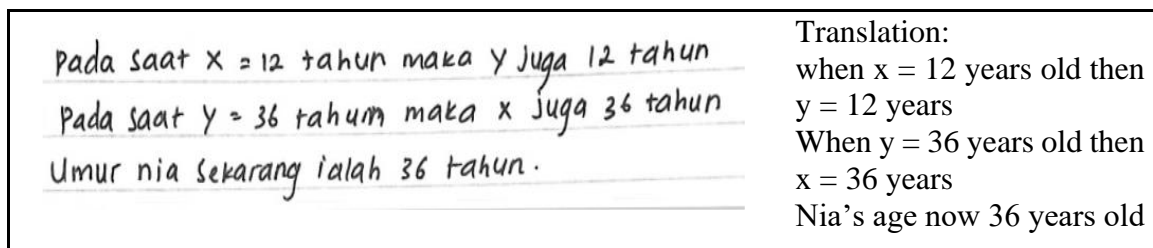

Figure 9. Problem-solving process of female participant (R2)

Confirmation of the AMA03 metacognitive activity was not achieved by implementing the think-aloud activity. R2 participant needs more awareness regarding the results of their decision-making process in choosing appropriate problem-solving techniques, as evidenced by the findings obtained through interviews. R2 has limited knowledge of identifying keywords to develop mathematical models. This investigation aimed to assess metacognitive activity. R2 participant indicated that he evaluated his ability to answer mathematical problems by stating, "Yes...I was able to solve it" while thinking aloud. The incorporation of interview activities enhances the efficacy of think-aloud. Verification of this metacognitive activity is not carried out during think-aloud activities. However, throughout the interview, it was confirmed that R2 lacked awareness of the relevant mathematical information about the situation. As a result, R2 does not articulate any knowledge relevant to the topic at hand. R2 concluded that this method was efficacious during a comprehensive metacognitive evaluation exercise. However, R2 expressed uncertainty regarding the suitability of the final solution obtained by applying the above

technique. Even though they did not encounter any challenges, R2 solved these problems. The following is a short excerpt from the interview.

- Q : *Are you aware of the results associated with independent thinking when selecting problem-solving strategies?*
 R2 : *Upon further reflection, I realised that naming 'keywords' facilitated the construction of mathematical models more efficiently.*
 Q : *How can you build confidence in your ability to solve problems?*
 R2 : *I can successfully solve existing problems until the desired results are achieved.*
 Q : *From your point of view, what mathematical knowledge is relevant to the subject?*
 R2 : *I am not sure and have not considered this.*
 Q : *Why?*
 R2 : *My approach primarily focuses on analysing problems and building connections based only on logical reasoning.*
 Q : *What is the reason behind assuming this technique is efficacious but still uncertain regarding the final solution?*
 R2 : *Even though I did not encounter significant challenges in solving the problem, I still determined the final solution because I was dissatisfied with the answers given.*

Figure 10 shows flowcharts of metacognitive activities carried out by R1 and R2 when solving mathematical problems based on mathematical modelling. Even though the metacognitive activities carried out by R1 and R2 are not significantly different regarding awareness, regulation, and evaluation, the variations in metacognitive activities are different in the aspects carried out.

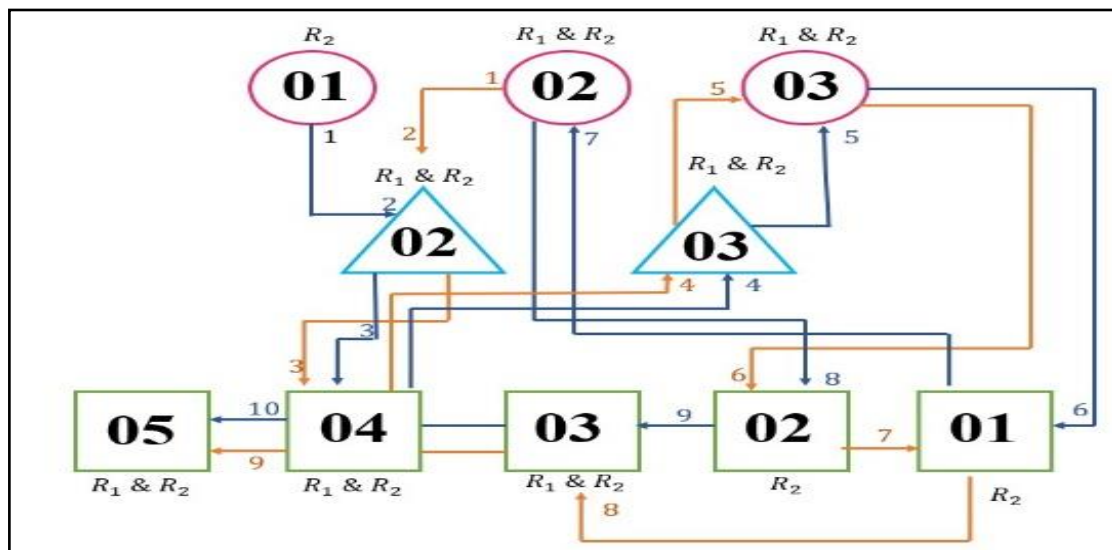

Figure 10. Flowchart of overall metacognitive activity variations in female participants

3.1.3. Description of variations in metacognitive activities of male participants (R3)

From the activities carried out, it can be concluded that R3 experiences all types of metacognitive activities. However, the activity most frequently carried out is evaluation, followed by awareness, and finally, regulation. A flowchart of variations in R3 participant metacognitive activities is presented in Figure 11.

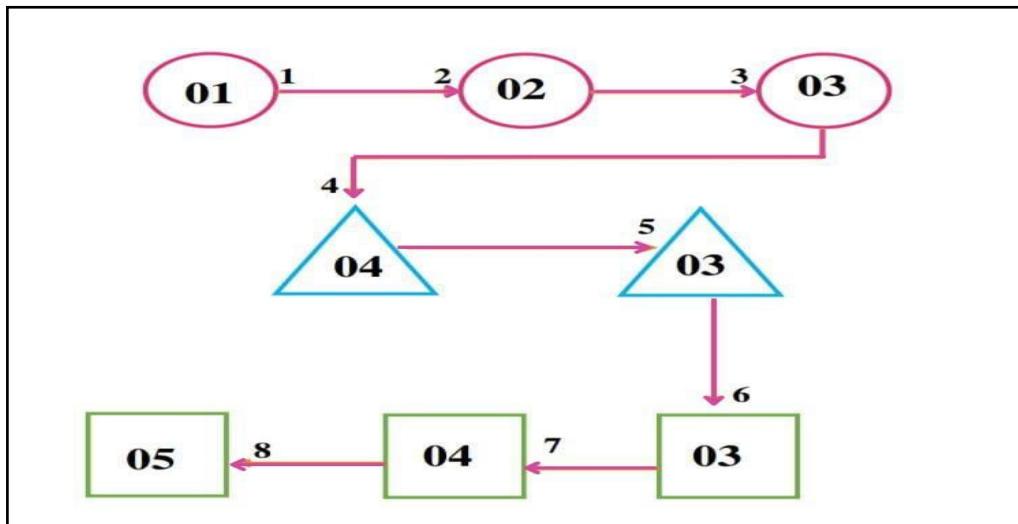

Figure 11. Flowchart of variations in metacognitive activities of male participants (R3)

Figure 11 explains the variation of metacognitive activities in participant R3 while solving math problems. Circle symbols with codes (01, 02, and 03) are marked as components of awareness metacognitive activity from each sub-indicator (AMA01, AMA02, and AMA03) (see Table 2). Triangular symbols with codes 04 and 03 are marked as components of regulatory metacognitive activity with the fourth and third sub-indicators (AMR04 and AMR03). Square symbols with codes 03, 04, and 05 are marked as components of evaluation metacognitive activity with the third, fourth, and fifth sub-indicators (AME03, AME04, and AME05). The process of metacognitive activity occurs in 8 stages.

In metacognitive awareness activities, R3 can understand all lexical units, including familiar and unfamiliar terms, and any relevant knowledge communicated explicitly. This understanding is facilitated through think-aloud exercises when individuals articulate their thoughts and reflections in response to specific questions. However, these activities were not documented on the answer sheet. To understand existing problems, R3 carried out difficulty readings repeatedly over a long period. This phenomenon has significant implications for the cultivation of cognitive awareness. R3 needs to gain awareness of the adequacy or completeness of the information it presents. Interviews, not think-aloud protocols, validate these activities. During metacognitive activities (AMA02), it was seen that R3 showed a lack of awareness of the results of their cognitive processes regarding mathematical problems. R3 is less confident when discussing questions; this shows that they are doubtful about its connection to algebraic concepts, namely linear equations. During metacognitive activities (AMA02), it was seen that R3 showed a lack of awareness of the results of their cognitive processes regarding mathematical problems. R3 is less confident when discussing questions; this shows that they are doubtful about its connection to algebraic concepts, namely linear equations. Verification of this exercise is not done through the think-aloud method but through interviews.

- Q : Do you know the adequacy of the information provided in dealing with this problem, whether it is insufficient, sufficient, or lacking?
 R3 : I should have recognised and reflected on this aspect because it took much time to understand the meaning of each phrase.
 Q : How much time do you use?
 R3 : I read the questions repeatedly for about 10 to 15 minutes.
 Q : What mathematical knowledge do you think is relevant to the subject?

R3 : *The algebra content could include linear equations, although, at that time, I did not consider that possibility.*

Q : *What prompted you to consider algebra content?*

R3 : *The math problem instructions require a mathematical model including variables, such as x and y , representing Nia and Andre's ages.*

Q : *Do you know the results of the independent cognitive process when choosing a problem-solving approach?*

R3 : *Upon reflection, I realised that defining 'keywords' facilitates the construction of a mathematical model for a particular situation.*

Participant R3 voiced uncertainty in choosing the proper problem-solving method during think-aloud activities. R3 explains the understanding gained from the problems encountered by illustrating examples of phrases that can be included in a mathematical framework. As confirmed by the think-aloud exercise, AMR03's regulatory activity in R3 indicates a high confidence level in aligning the solution and the chosen strategy. R3 determined Nia's age by applying an elimination approach and analysing the given equation. The following section presents the results of the interviews.

Q : *What factors contribute to the expression of uncertainty when selecting and determining appropriate problem-solving strategies?*

R3 : *The need for a clear plan adds to my perception that there is no definite solution to the problem. I repeatedly reviewed the statements to understand each one.*

Q : *What actions are taken to understand each of these statements?*

R3 : *Created an illustrative example and formulated a mathematical model based on my understanding.*

Q : *How can you ensure the solutions implemented are aligned with the existing problems?*

R3 : *I followed the steps specified. After that, I used the elimination method (eliminating the variable x) to determine the value of n . Then, substitute the value $n=12$ into the equation $x - 12 = n$. Then I substituted the n value into equation $36 - x = n$, and the result matched, namely $x = 24$. So, it can be concluded that Nia's current age is 24 years (see [Figure 12](#)).*

	<p>Translation:</p> <p>Let us suppose that the age of Nia is now</p> $x - 12 = n \dots (1)$ $36 - x = n \dots (2)$ <p>Substitute $n = 12$ into the first equation</p> $x - 12 = 12$ $x - 12 + 12 = 12 + 12$ $x = 24$ <p>Therefore, Nia is now 24 years old.</p>
--	--

Figure 12. Problem-solving process of participants (R3)

Assessment of overall metacognitive activity is demonstrated through the implementation of think-aloud exercises. R3 has a self-perception of competence in solving mathematical problems and facing challenges in understanding and interpreting the meaning of individual terms. R3 also expressed uncertainty regarding the results due to doubts regarding the chosen problem-solving technique. R3 demonstrated a confident approach to

overcoming adversity, responding to doubts regarding its accuracy. The solution provided shows that the value of x is equal to 24, thus implying that Nia's current age is 24 years (see Figure 12). The response given by R3 needs to be more accurate. Below are excerpts from the interview.

Q : What factors contributed to your challenges in understanding the issues presented?

R3 : The complexity of the vocabulary and sentence structures used in the text requires a long time to solve the problem effectively.

3.1.4. Description of variations in metacognitive activities of male participants (R4)

An explanation of the metacognitive actions carried out by participant R4 is also provided, considering the sequential changes that occurred. Figure 13 shows the flow of variations in metacognitive activities carried out by participant R4 when solving mathematical problems. It can be concluded that the activities most frequently carried out by R4 are awareness, evaluation, and regulation.

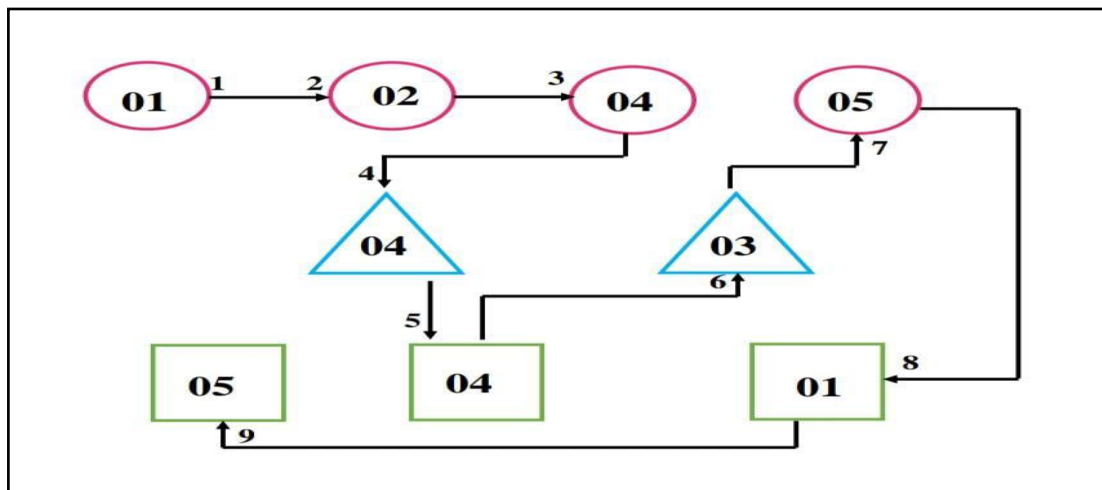

Figure 13. Flowchart of variations in the metacognitive activity of male participants (R4)

Variations in metacognitive activities in participant R4 while solving mathematical problems focused more on awareness of metacognitive activities with sub-indicators AMA01, AMA02, AMA04, and AMA05 (see Figure 13). While regulatory metacognitive activities only occur in sub-indicators AMR04 and AMR03. Similarly, evaluation metacognitive activity occurs only in sub-indicators AME04, AME01, and AME05. The process of metacognitive activity has nine stages, marked with black arrows.

Metacognitive awareness activities (AMA01) indicated that R4 comprehensively understood the vocabulary and content presented, as evidenced by their articulate verbalisations during the think-aloud exercise. R4 engaged in repeated reading with difficulty understanding issues given in less than 10 minutes. According to R4, the material provided is highly complex, so it isn't easy to understand each statement. During AMA02's metacognitive activities, he became aware that the results of his cognitive processes were related to mathematical knowledge applied to the given challenges. According to R4, knowledge about problems can be represented by linear equations, a finding confirmed through think-aloud activities. Identification of metacognitive activity in AMA03 does not occur through think-aloud exercises. R4 needs to be made aware of the results of his cognitive processes when considering the steps necessary to overcome these challenges. The quotes provided relate to the interview.

Q : *Are you aware of the results obtained from your cognitive processes when thinking about the steps required to solve a math problem?*

R4 : *I need more awareness or understanding about something. My first goal is to concentrate on understanding the given problem.*

Confirmation of regulatory metacognitive action of AMR04 has not been demonstrated. During the interview, R4 revealed their approach to solving this problem using a number line, as depicted in [Figure 14](#). Based on the information provided, it appears that R4 uses a problem-solving approach involving a number line. AME04 metacognitive evaluation activities were verified by carrying out think-aloud activities. R4 experienced quite significant challenges in solving mathematical problems. Metacognitive processes are carried out by participant R4, which was validated by applying the think-aloud protocol. R4 uses a systematic approach to determine the following actions for problem-solving. This involves carefully reading and understanding the problem statement, establishing connections between the information obtained and the concept of linear equations, using visual aids as a number line to explain the appropriate mathematical model, and ultimately solving the problem. The above excerpt presents a segment of the interview.

Q : *Can you justify the compatibility of a solution using a number line with the given problem?*

R4 : *Indeed, the use of the number line is quite understandable.*

Q : *Explain the procedural steps in presenting a number line to build a mathematical model.*

R4 : *Initially, I drew two number lines. The first number in the line illustrates that at one point, Nia's current age was equivalent to Andre's when he became Nia's current age. This proposition is represented by variables A (Andre), N (Nia), and x (age distance between Andre and Nia) (see [Figure 14](#)).*

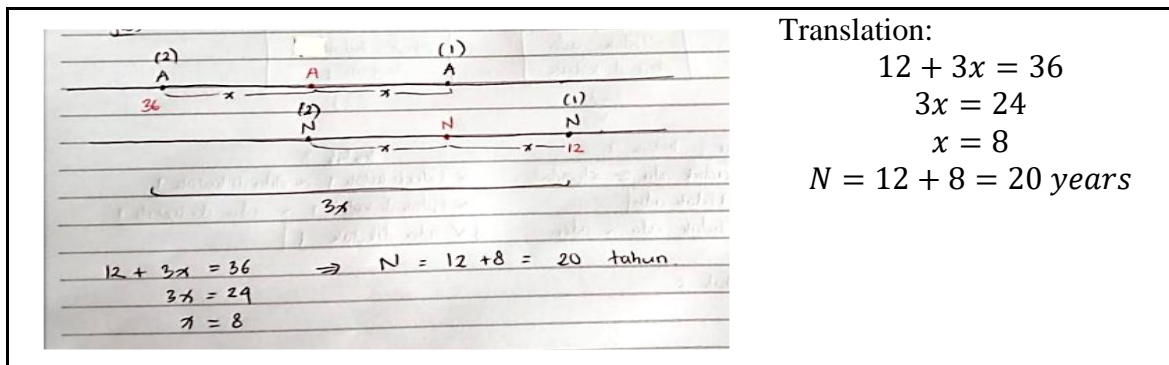

Figure 14. Problem-solving process of male participants (R4)

Metacognitive activity AMA05 was verified. R4 achieved the results of his cognitive process in completing the challenge. R4 realised that using a number line would result in more convincing problem-solving despite facing challenges during the problem-solving attempt. Confirmation of metacognitive activities in the overall evaluation was achieved through the use of think-aloud activities. It was found that R4 could evaluate his aptitude in solving the mathematical problems offered despite the uncertainty. However, R4 revealed a degree of uncertainty regarding the final solution provided for a particular situation. Based on the data presented in [Figure 14](#), it can be concluded that the response given by R4 is accurate, meaning that Nia's current age is 20 years.

The variations in metacognitive activities showed that female participants carried out metacognitive regulatory activities that were simple enough. Metacognitive regulatory activities identified were only in 'determining other strategies to use' and determining the following action. Previous research findings state that metacognitive regulation is a guide when evaluating interventions carried out to encourage the occurrence of specific regulatory skills (De Backer et al., 2016). Furthermore, the evaluation metacognitive activity aspect 'assessing the difficulties faced' was identified when female participants before the regulatory metacognitive activity 'determining the next action' occurred. This shows that some evaluation activities occur at the beginning, while evaluation activities in other aspects occur systematically in the problem-solving process. The overall variety of metacognitive activities that occur are simple and structured.

Apart from that, male participants' metacognitive activities also varied when solving mathematical problems. However, the variations identified were more complex in the metacognitive activities of consciousness than in other activities. Metacognitive regulatory activities were only identified in 'determining the next action to solve the problem' and choosing a 'problem-solving strategy' (see Figure 15). Meanwhile, the overall evaluation of metacognitive activities was partially identified, but there were different variations between male participants and each other (see Figure 15).

Male participant's metacognitive awareness activities were well identified. Participants understand the problem well and connect the knowledge they have by using the right strategy. Male participants have good representational skills in modelling the issues presented. This finding aligns with research by Ramlah et al. (2023) that male students have good representation skills in identifying mathematical problems. Modelling activities are essential in developing metacognitive thinking (Kandemir & Karadeniz, 2021). In other words, metacognitive awareness activities are critical because they impact the results of solving problems based on mathematical models. Metacognitive awareness relates to activities that help people control their thoughts and learning (Muhali et al., 2019).

The difference in variations in metacognitive activities between the two is that female participants are more complex and structured in evaluation activities. In contrast, male participants are more complicated and structured in awareness activities (Figures 10 and 15). More variations in metacognitive activities were identified among female participants than male participants. Female students tend to be more careful in metacognitive activities and identifying errors when solving problems Yurt (2022). The similarity is that they have weaknesses in the regulatory aspect of metacognitive activities.

Metacognitive awareness activities are the primary determinant of a person's success in learning (Abdelrahman, 2020). Metacognitive awareness is related to activities that can help people control their thinking (Muhali et al., 2019). Metacognitive awareness activities among female participants were less identified in think-aloud activities. Female participants needed to be more optimal in metacognitive awareness activities and estimated results less precisely than male participants. Participants did not recognise mindfulness as a metacognitive activity. This finding aligns with research by Magiera and Zawojewski (2011), which revealed that participants underreported awareness in think-aloud because they did not have competent knowledge about metacognition (Temur et al., 2019). The lack of metacognitive awareness activities by female participants in solving mathematical problems based on mathematical models impacts the final decisions that need to be more precise (McCabe, 2011; Viseu et al., 2020).

Other findings reveal that male students have better metacognitive skills than female students. Meanwhile, other findings reveal that female students have better metacognitive skills and are careful in planning, monitoring, and evaluating strategies (Yurt, 2022).

In general, it can be concluded that female participants carry out more varied metacognitive activities than male participants, but all participants have a variety of unstructured metacognitive activities. These differences may occur due to various factors, such as differences in situations faced, orientation towards tasks, learning strategies, learning experiences, and mathematical abilities. This is reinforced by previous research findings, which state that variations in metacognitive activities can be complex and structured based on situations, such as metacognitive reflection, discussion between students, teacher support, and emotional support (Rahman et al., 2010). Different variations in metacognitive activity were identified among these factors due to differences in comprehension abilities, mathematical representation, and orientation toward tasks.

In carrying out metacognitive activities to solve problems using mathematical models, students need to integrate the mathematical knowledge they have learned with their metacognitive abilities to produce reasonable solutions. One of the problems faced by prospective teacher students in solving mathematics problems is the need for metacognitive activities. Metacognitive activities that could be more optimal can help students understand mathematical problems and find the right strategy to solve these problems. The metacognitive activities are influenced by a person's thinking characteristics (Wilson & Clarke, 2004). Metacognitive considerations influence a person's finding a solution to a problem (Erkan & Kar, 2022). This can hinder their ability to solve problems. Additionally, other research reveals that pre-service teachers need help identifying difficulties with math problems when planning appropriate solutions (Hiebert & Wearne, 1996). This shows the need for more effectiveness of metacognitive activities in solving mathematical problems. Thus, student teachers need to increase their metacognitive activities in solving mathematical problems based on mathematical models to overcome these problems and train their abilities in teaching mathematics in the future. They must also be ready to understand teaching and design suitable mathematical modelling tasks.

The similarity of the results of this research with research conducted by Wilson and Clarke (2004) and Whitebread et al. (2007) is that more metacognitive activities are identified during problem-solving, namely evaluation followed by regulation and then awareness. Other research discusses students' metacognitive behaviour in solving mathematical modelling problems (Hidayat et al., 2018; Hidayat et al., 2020).

The findings of this research fill the gap in the study of Hastuti et al. (2016) and Panjaitan (2016), which only describe shifts in metacognitive activity and variations in metacognitive evaluation that occur during group discussion activities to solve mathematical problems, so they have not comprehensively explored the variations in metacognitive activity that happen in each individual. This means that variations can see differences in metacognitive activity, while shifts only see changes in activity that occur. Variations in non-complex and structured metacognitive activities can be reduced through situations according to the type of problem, metacognitive abilities, and so on. Applying a learning model or approach can reduce variation in metacognitive activities and success in solving problems. Another difference in this research is the type of mathematics problems presented. Where previous research has yet to emphasise problems that require mathematical modelling to solve them. The findings of prior research, which examined the metacognition of prospective cognitive-style mathematics teachers, stated that there needed to be more variation in metacognitive activities at each problem-solving step. Variations in metacognitive activities were only identified when evaluating metacognitive activities (Panjaitan, 2016).

4. CONCLUSION

The main focus of this research is to report and specifically describe variations in the metacognitive activities of prospective mathematics teachers based on gender when solving mathematical problems using mathematical modelling. Previous research only reported metacognitive abilities, metacognitive skills, students' metacognitive strategies in solving mathematical and other issues, metacognitive activities in solving problems in general, variations in metacognitive activities in the evaluation aspect, and shifts in metacognitive activities that occurred during discussion activities to solve a problem.

To these conditions, a more specific study is needed regarding variations in metacognitive activities in solving problems based on mathematical modelling as a breakthrough to add to and complement more specific literature studies than before. They are exploring variations in metacognitive activities for awareness, regulation, and evaluation of prospective mathematics teachers based on gender. In essence, there are differences in variations in metacognitive activities between female and male prospective teacher students, identified explicitly through the mathematical modelling-based problem-solving tasks.

This research shows variations in the metacognitive activities of female and male prospective teacher students in the awareness and evaluation components, which are influenced by differences in mathematical understanding, mathematical representation, and orientation towards a task. Awareness of metacognitive activities determines the success or failure of prospective teachers in obtaining solutions to mathematical modelling problems and is the first aspect of metacognitive activities.

ACKNOWLEDGEMENTS

The authors would like to express their appreciation to the Directorate of Resources, Directorate General of Higher Education, Ministry of Education and Culture of the Republic of Indonesia for providing financial support for this research from 2020 to 2022. Additionally, the authors acknowledge Prof. Dwi Juniati, M.Si., for granting permission to adapt her mathematical problem-solving task instrument. Lastly, the authors thank the students of Universitas Singaperbangsa Karawang for their valuable contributions to the data collection in this study.

REFERENCES

- Abdelrahman, R. M. (2020). Metacognitive awareness and academic motivation and their impact on academic achievement of Ajman University students. *Heliyon*, 6(9), e04192. <https://doi.org/10.1016/j.heliyon.2020.e04192>
- Al Shabibi, A. A., & Alkharusi, H. (2018). Mathematical problem-solving and metacognitive skills of 5th grade students as a function of gender and level of academic achievement. *Cypriot Journal of Educational Sciences*, 13(2), 385-395.
- Alifiani, A., & Faradiba, S. S. (2021). Mathematics pre-service teacher's metacognitive failure in mathematics online learning. *Jurnal Riset Pendidikan Matematika*, 8(2), 179-190. <https://doi.org/10.21831/jrpm.v8i2.43366>
- Bakar, S. A., Salim, N. R., Ayub, A. F. M., & Gopal, K. (2021). Success indicators of mathematical problem-solving performance among Malaysian matriculation students. *International Journal of Learning, Teaching and Educational Research*, 20(3), 97-116. <https://doi.org/10.26803/ijlter.20.3.7>

- De Backer, L., Van Keer, H., Moerkerke, B., & Valcke, M. (2016). Examining evolutions in the adoption of metacognitive regulation in reciprocal peer tutoring groups. *Metacognition and Learning*, 11(2), 187-213. <https://doi.org/10.1007/s11409-015-9141-7>
- Desoete, A., Roeyers, H., & Buysse, A. (2001). Metacognition and mathematical problem solving in grade 3. *Journal of Learning Disabilities*, 34(5), 435-447. <https://doi.org/10.1177/002221940103400505>
- Erkan, B., & Kar, T. (2022). Pre-service mathematics teachers' problem-formulation processes: Development of the revised active learning framework. *The Journal of Mathematical Behavior*, 65, 100918. <https://doi.org/10.1016/j.jmathb.2021.100918>
- Flavell, J. H. (1979). Metacognition and cognitive monitoring: A new area of cognitive–developmental inquiry. *American psychologist*, 34(10), 906-911. <https://doi.org/10.1037/0003-066X.34.10.906>
- Goos, M. (2002). Understanding metacognitive failure. *The Journal of Mathematical Behavior*, 21(3), 283-302. [https://doi.org/10.1016/S0732-3123\(02\)00130-X](https://doi.org/10.1016/S0732-3123(02)00130-X)
- Gurat, M., & Medula Jr, C. (2016). Metacognitive strategy knowledge use through mathematical problem solving amongst pre-service teachers. *American Journal of Educational Research*, 4(2), 170-189.
- Händel, M., Artelt, C., & Weinert, S. (2013). Assessing metacognitive knowledge: Development and evaluation of a test instrument. *Journal for educational research online*, 5(2), 162-188. <https://doi.org/10.25656/01:8429>
- Hastuti, I. D., Nusantara, T., Subanji, S., & Susanto, H. (2016). Constructive metacognitive activity shift in mathematical problem solving. *Educational Research and Reviews*, 11(8), 656-667.
- Hidayat, R., Zamri, S. N. A. S., & Zulnaidi, H. (2018). Does mastery of goal components mediate the relationship between metacognition and mathematical modelling competency? *Educational Sciences: Theory and Practice*, 18(3), 579-604.
- Hidayat, R., Zamri, S. N. A. S., Zulnaidi, H., & Yuanita, P. (2020). Meta-cognitive behaviour and mathematical modelling competency: mediating effect of performance goals. *Heliyon*, 6(4), e03800. <https://doi.org/10.1016/j.heliyon.2020.e03800>
- Hiebert, J., & Wearne, D. (1996). Instruction, understanding, and skill in multidigit addition and subtraction. *Cognition and Instruction*, 14(3), 251-283. https://doi.org/10.1207/s1532690xci1403_1
- Juniati, D. (2020). *Fuzzy mathematics*. Course assignment. State University of Surabaya.
- Kandemir, M., & Karadeniz, I. (2021). Pre-service teachers' cognitive and metacognitive processes in integrated STEM modeling activity. *Journal of Education in Science Environment and Health*, 7(2), 104-127. <https://doi.org/10.21891/jeseh.832574>
- Kaune, C., Cohors-Fresenborg, E., & Nowinska, E. (2011). Development of metacognitive and discursive activities in Indonesian maths teaching: A theory based design and test of a learning environment. *Journal on Mathematics Education*, 2(1), 15-40. <https://doi.org/10.22342/jme.2.1.777.15-40>
- Kayashima, M., Inaba, A., & Mizoguchi, R. (2005). What do you mean by to help learning of metacognition? In Proceedings of the 2005 conference on Artificial Intelligence

- in Education: Supporting Learning through Intelligent and Socially Informed Technology, (pp. 346–353).
- Khasanah, N. (2021). Analisis kemampuan pemecahan masalah matematis siswa quitters ditinjau dari kemampuan metakognitif [Analysis of quitters' mathematical problem solving abilities in terms of metacognitive abilities]. *Pythagoras: Jurnal Pendidikan Matematika*, 16(1), 44-58. <https://doi.org/10.21831/pg.v16i1.34509>
- Laamena, C. M., & Laurens, T. (2021). Mathematical literacy ability and metacognitive characteristics of mathematics pre-service teacher. *Infinity Journal*, 10(2), 259-270. <https://doi.org/10.22460/infinity.v10i2.p259-270>
- Magiera, M. T., & Zawojewski, J. S. (2011). Characterizations of social-based and self-based contexts associated with students' awareness, evaluation, and regulation of their thinking during small-group mathematical modeling. *Journal for Research in Mathematics Education JRME*, 42(5), 486-520. <https://doi.org/10.5951/jresematheduc.42.5.0486>
- McCabe, J. (2011). Metacognitive awareness of learning strategies in undergraduates. *Memory & Cognition*, 39(3), 462-476. <https://doi.org/10.3758/s13421-010-0035-2>
- Miles, M. B., Huberman, A. M., & Saldaña, J. (2014). *Qualitative data analysis a methods sourcebook*. SAGE Publications, Inc.
- Muhali, M., Yuanita, L., & Ibrahim, M. (2019). The validity and effectiveness of the reflective-metacognitive learning model to improve students' metacognition ability in Indonesia. *Malaysian Journal of Learning and Instruction*, 16(2), 33-74. <https://doi.org/10.32890/mjli2019.16.2.2>
- Ozturk, N. (2016). An analysis of pre-service elementary teachers' understanding of metacognition and pedagogies of metacognition. *Journal of Teacher Education and Educators*, 5(1), 47-68.
- Panaoura, A., & Philippou, G. (2005). The mental models of similar mathematical problems: A strategy for enhancing pupils self-representation and self-evaluation In Proceedings of the International Symposium Elementary Mathematics Teaching, (pp. 252-260).
- Panjaitan, B. (2016). Metakognisi calon guru bergaya kognitif reflektif dan kognitif impulsif dalam memecahkan masalah matematika [Metacognition of prospective teachers with reflective cognitive style and impulsive cognitive style in solving mathematical problems]. *Cakrawala Pendidikan*, XXXV(2), 244-253. <https://doi.org/10.21831/cp.v15i2.9463>
- Pathuddin, P., Ketut Budayasa, I., & Lukito, A. (2019). Metacognitive activity of male students: difference field independent-dependent cognitive style. *Journal of Physics: Conference Series*, 1218(1), 012025. <https://doi.org/10.1088/1742-6596/1218/1/012025>
- Permadi, H., & Irawati, S. (2023). Metacognitive intervention: Can it solve suspension of sense-making in integration problem-solving? *Mathematics Teaching Research Journal*, 15(1), 44-66.
- Rahman, S., Yasin, R. M., Ariffin, S. R., Hayati, N., & Yusoff, S. (2010). Metacognitive skills and the development of metacognition in the classroom In International Conference on Education and Educational Technologies, (pp. 347-351).

- Ramlah, R., Abadi, A. P., Aisyah, D. S., Lestari, K. E., & Yudhanegara, M. R. (2023). Digital puzzle worksheet for identifying metacognition level of students: A study of gender differences. *European Journal of Educational Research*, 12(2). <https://doi.org/10.12973/eu-jer.12.2.795>
- Schoenfeld, A. H. (1987). *Cognitive science and mathematics education*. Routledge. <https://doi.org/10.4324/9780203062685>
- Stillman, G. A., & Galbraith, P. L. (1998). Applying mathematics with real world connections: metacognitive characteristics of secondary students. *Educational Studies in Mathematics*, 36(2), 157-194. <https://doi.org/10.1023/A:1003246329257>
- Temur, Ö. D., Özsoy, G., & Turgut, S. (2019). Metacognitive instructional behaviours of preschool teachers in mathematical activities. *Zdm*, 51(4), 655-666. <https://doi.org/10.1007/s11858-019-01069-1>
- van Someren, M. W., Barnard, Y. F., & Sandberg, J. A. C. (1994). *The think aloud method: A practical guide to modelling cognitive processes*. Academic Press.
- Viseu, F., Martins, P. M., & Leite, L. (2020). Prospective primary school teachers' activities when dealing with mathematics modelling tasks. *Journal on Mathematics Education*, 11(2), 301-318. <https://doi.org/10.22342/jme.11.2.7946.301-318>
- Wallace, M. P., Li, V. M., Huang, T. C., & He, N. C. (2021). Metacognitive strategy use for EFL readers: Differences in gender and reading ability. *TESL-EJ: The Electronic Journal for English as a Second Language*, 25(2), 1-22.
- Whitebread, D., Bingham, S., Grau, V., Pasternak, D. P., & Sangster, C. (2007). Development of metacognition and self-regulated learning in young children: Role of collaborative and peer-assisted learning. *Journal of Cognitive Education and Psychology*, 6(3), 433-455. <https://doi.org/10.1891/194589507787382043>
- Wilson, J., & Clarke, D. (2004). Towards the modelling of mathematical metacognition. *Mathematics Education Research Journal*, 16(2), 25-48. <https://doi.org/10.1007/BF03217394>
- Yıldız, N., & Dökme, İ. (2017). The effect of metacognition instruction on solving mathematical problems in science lessons. *Journal of Educational and Instructional Studies in the World*, 7(4), 69-75.
- Yurt, E. (2022). The mediating role of metacognitive strategies in the relationship between gender and mathematical reasoning performance. *Psycho-Educational Research Reviews*, 11(2), 98-120. https://doi.org/10.52963/PERR_Biruni_V11.N2.07
- Zan, R. (2000). A metacognitive intervention in mathematics at university level. *International Journal of Mathematical Education in Science and Technology*, 31(1), 143-150. <https://doi.org/10.1080/002073900287462>

